









FL SERIE SPEZIFICATION

MASCHINENTYP [FL]	330	440	660
Kapazität [kg/h]	1500	4000	8000
Schneiddicken [mm]	25x420x650	25x420x650	350x650x810
Schneiddicken	niedrige Klinsen - 3,6,9 mm hohe Klinsen - 14,17,20 mm	niedrige Klinsen - 3,6,9 mm hohe Klinsen - 14,17,20 mm	niedrige Klinsen - 3,6,9 mm hohe Klinsen - 14,17,20 mm
Anzahl der Schneidklinsen	4 Stück (hohe Klinsen im Set)	4 Stück (hohe Klinsen im Set)	7 Stück (hohe Klinsen im Set)
Geschwindigkeit der Schneidtrommel [rpm]	130	I-70 II-40	112
Motorleistung [kW]	7,5	9,2/11,5	18,5
Standardspannung	400,50	400,50	400,50
Standardsteuerung			
Mischer Nettogewicht [kg]	590	980	1860
Sicherung [A]	20	32	50
Beschickung option	-	PZ 3/250	PZ 3/250
Schneiden zu	200L 	200L 	dolav 
Deckel öffnen/ Schließen			
Erforderlicher Druck [bar]	-	6	6
Verarbeitungstemperatur	-30%	-30%	-30%

MODELL DER MASCHINEN [FL]	330	440	660
Beschickung option	-	o	o
Tastenbedienfeld	S	S	S

FL SERIE SPEZIFIKATION

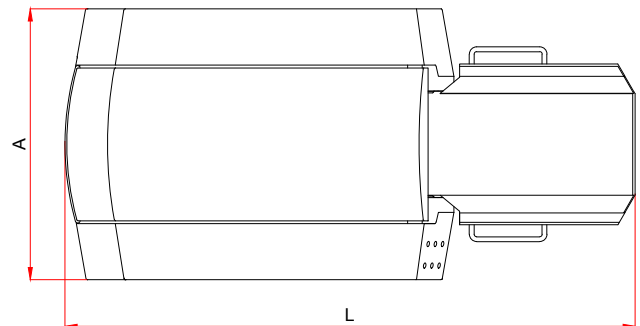
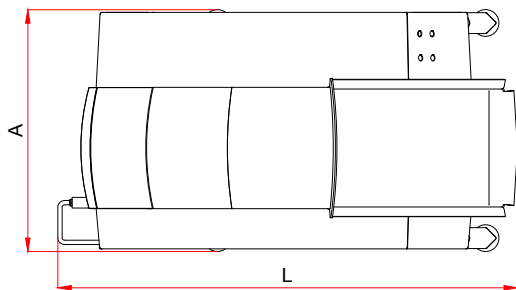
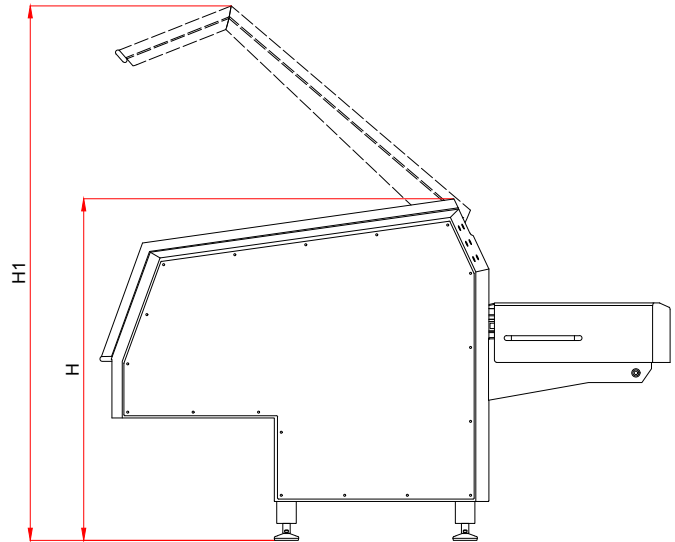
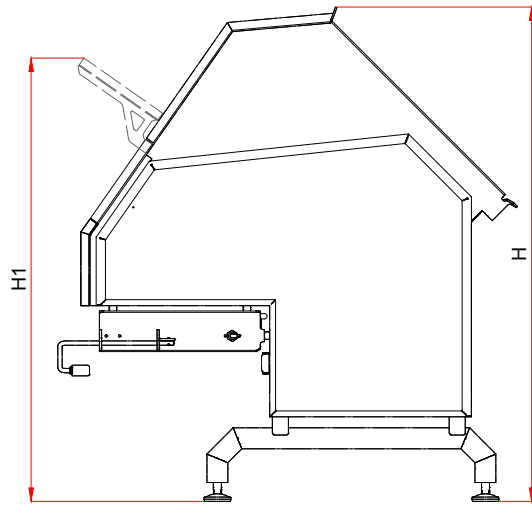

FL 330

FL 440 & FL 660

MODELL DER MASCHINEN [FL]	330	440	660
H [cm]	185	141	178
H1 [cm]	166	211	269
L [cm]	172	236	295
A [cm]	90	112	160